



The Sonata Residential Ultrasonic water meter is Master Meter's next step in unifying our ultrasonic solid-state measurement profile. Utilizing advanced ultrasonic flow measurement, the Sonata greatly improves low flow measurement compared to residential mechanical meters, making it an ideal solution for addressing Non-Revenue Water (NRW). The Sonata is fully Internet of Things (IoT) ready and capable of meeting the challenges of tomorrow's smart water networks.

#### Technical Specifications:

**AWWA Standard:** Meets or exceeds all sections of the most recent revision of ANSI/AWWA Standard C700 and C708. Meets or exceeds ISO 4064 rev. 2005.

**NSF / ANSI Standard:** Compliant with NSF/ANSI 372, NSF/ANSI 61, and Safe Drinking Water Act (SDWA).

**Working Pressure:** 175 PSI

**Liquid Temperature:** 32.1° F 122° F

**Ambient Temperature:** -13° F 131° F for the display

**Power Source:** One C Cell Lithium Thionyl Chloride battery powers the meter and a secondary C Cell battery powers the communication module.

**Environmental Protection:** Factory potted design provides NEMA 6P (IP68) for meter pit submersion.

#### Features & Benefits:

- Flow sensitivity starting as low as 1/32 GPM. Powerful solution to reduce non-revenue water.
- Compliant with Safe Drinking Water Act (SDWA).
- No moving parts for lifetime accuracy.
- 20 year battery life.
- Patent-pending obstruction free flow tube minimizes head loss and risk of damage to sonic reflectors.
- Detailed LCD features totalized flow, rate of flow, battery alarm, leak alarm, burst pipe alarm, and tamper alarm.
- Fully submersible; IP68 design.
- Optional Internal RF module for Master Meter 3G AMR System.
- Optional 3 wire cable with wired pigtail, Nicor plug, or Itron Connector, allowing connectivity to third-party AMI or AMR systems.
- Install in a wide variety of positions; horizontal, vertical, or inclined.
- IoT ready for connectivity to Smart City Networks.



**Technical Specs (Cont'd):**

- **Display Units:** Multi line 9 digit LCD (Programmable flow measurement in USG, Cubic Feet, or Cubic Meters. Rate of Flow available in GPM, Lt/s, Lt/m, M<sup>3</sup>/h)
- **Output Protocol:** Encoder UI-1203 Protocol.
- **Output Configuration:** Internal 3G RF module, cable with wired pigtail, cable with Nicor Plug, or cable with Itron Connector.
- **Data Logging:** Internal data logger with consumption reports with full alarms and events, which include Leak, Burst Pipe, Backflow, Dry Pipe, Tamper, and Freeze Risk.
- **Construction Material:** Lead-free construction, reinforced Polyphenylene Sulfide (PPS) composite design.
- **Flow Tube:** Patent-pending design and operation of the flow tube utilizes reinforced fins to minimize body expansion. Using a "Z" shape sonic beam flight pattern, sound waves are directed along the wider axis of the flow tube and aligned with the majority of the fluid flow. This oblong design of the flow tube minimizes flow disruptions near the transducers, such as cavitation, swirls, and eddies to ensure a wider range of meter accuracy. Moving the transducers to the side walls of the flow tube, rather than on the top of the flow tube, places wide beam ultrasonic soundwaves out of the general path of entrained air bubbles, which typically move to the top of an internal surface.
- **Optional:** Strainer or check valve that may be installed inside the flow tube.

**Operating Characteristics and Dimensions:**

Sonata Operating Characteristics and Dimensions	5/8" (15 mm)	5/8" x 3/4" (15 x 20 mm)	3/4" Short (20 mm)	3/4" Long (20 mm)	1" (25 mm)
<b>Safe Maximum Operating Capacity</b>	25 GPM (5.7 m <sup>3</sup> /h)	35 GPM (7.9 m <sup>3</sup> /h)	45 GPM (10.2 m <sup>3</sup> /h)	45 GPM (10.2 m <sup>3</sup> /h)	55 GPM (12.5 m <sup>3</sup> /h)
<b>Normal Operating Range</b> (98.5% - 101.5% Accuracy)	0.10 – 25 GPM (0.023 – 5.7 m <sup>3</sup> /h)	0.10 – 35 GPM (0.023 – 7.9 m <sup>3</sup> /h)	0.10 – 45 GPM (0.023 – 10.2 m <sup>3</sup> /h)	0.10 – 45 GPM (0.023 – 10.2 m <sup>3</sup> /h)	0.38 – 55 GPM (0.09 – 12.5 m <sup>3</sup> /h)
<b>Extended Low Flow</b> (97% - 103% Accuracy)	0.03 GPM (0.007 m <sup>3</sup> /h)	0.05 GPM (0.01 m <sup>3</sup> /h)	0.05 GPM (0.01 m <sup>3</sup> /h)	0.05 GPM (0.01 m <sup>3</sup> /h)	0.11 GPM (0.025 m <sup>3</sup> /h)
<b>L - Length</b>	7-1/2" (190 mm)	7-1/2" (190 mm)	7-1/2" (190 mm)	9" (229 mm)	10-3/4" (273 mm)
<b>W - Width</b>	3" (80 mm)	3" (80 mm)	3" (80 mm)	3" (80 mm)	3" (82 mm)
<b>H - Height</b>	4-1/2" (117 mm)	4-1/2" (117 mm)	4-1/2" (117 mm)	4-1/2" (117 mm)	4-3/4" (121 mm)
<b>h - Height from Center Pipe</b>	3" (80 mm)	3" (80 mm)	3" (80 mm)	3" (80 mm)	3-1/4" (82 mm)
<b>C - Depth from Center Pipe</b>	1-1/2" (37 mm)	1-1/2" (37 mm)	1-1/2" (37 mm)	1-1/2" (37 mm)	1-1/2" (37 mm)
<b>Weight</b>	2 lbs (0.9 kg)	2 lbs (0.9 kg)	2 lbs (0.9 kg)	2 lbs (0.9 kg)	2.25 lbs (1 kg)

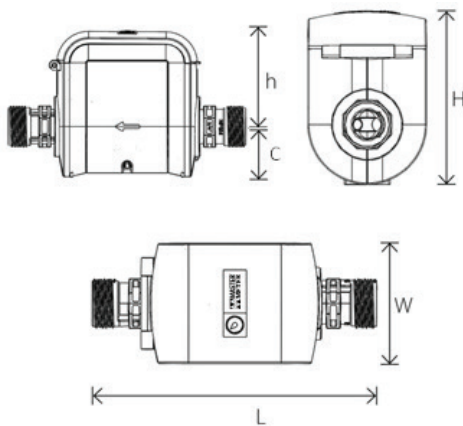

Master Meter, Inc.

Toll Free: 800.765.6518

Fax: 817.842.8100

innovate@mastermeter.com